

## SAFETY INSTRUCTIONS

Pay particular attention to the signs and their symbols



General danger to people



Warning of electrical voltage

### ATTENTION!

Danger to equipment and operation

This appliance can be used by children aged 8 years or over and by persons with limited physical, sensory or intellectual capabilities, or with limited experience and knowledge, provided that they are supervised or have been instructed in the safe use of the appliance and are aware of the dangers involved. Children must not be allowed to play with the appliance. Cleaning and user maintenance must not be carried out by children unless they are supervised.

Before assembling, carefully read the contents of this manual. The non-observance of the instructions will result in the annulment of the warranty.

## GENERAL INFORMATION

Our pressurization groups are manufactured for pumping clean water. They must be installed in places protected from bad weather and ice, well ventilated and in non-dangerous environment.

Each of our groups is entirely tested in our establishments.

Upon delivery, check that the group has not suffered any damage during transportation; in this case, contact immediately the retailer. In case of claims, contact immediately the retailer within ten days of purchase.

## LIMIT OF USE

**ATTENTION!** Before checking the pumps priming make sure that their max. pressure, shown on their nameplate, is compatible both with the system pressure and with its devices. Furthermore make sure that eventual security valves are set to have an higher intervene pressure than the max. pressure of the pumps.

**ATTENTION!** The group is not suitable for pumping chemical-ly aggressive or flammable liquids.

**ATTENTION!** Avoid any dry-operating of the motor pump.

### Temperature

Maximum temperature of the pumped liquid: 40°C

Maximum ambient temperature: 40°C, (50°C per le elettropompe DHR, VLR)

## INSTALLATION

Assembly diagrams normally used

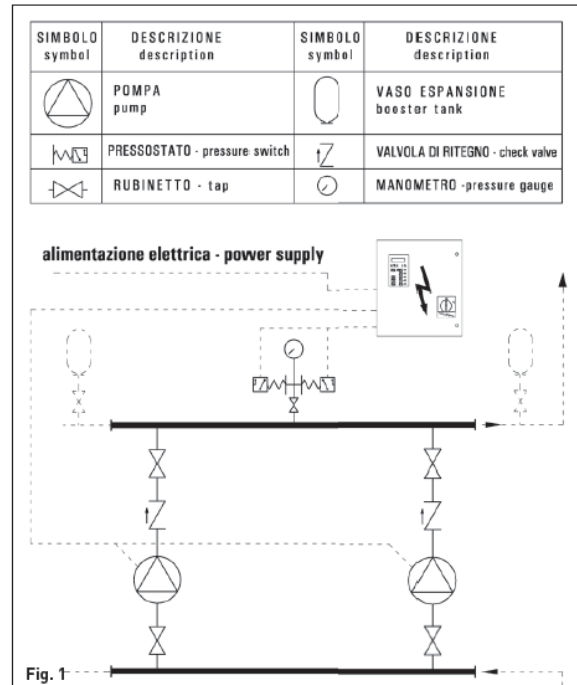

All the assembly operations must be carried out with group disconnected from the power grid.

In the case where the pressurization group is fed by a tank, avoid any unpriming phenomena; we recommend to control the following characteristic data:

- Static level (initial level of the well)
- Dynamic level (level reached during the group operation)
- Flow rate
- Hmax suction

To reduce losses during replenishment it is necessary to install the group as close as possible to the pumping point and to install a suction pipe with a minor number of curvatures that should have a sufficiently wide radius.

Even the diameter of the pipe should be calculated so as to reduce load losses, what requires dimensions greater than or equal to those of the pump aspiration inlet.

In order to avoid the formation of air locks into the suction pipes, these ones must have a positive gradient, from bottom to top, avoiding counter gradients or "goosenecks", and there must not any air infiltration in the connections.

Connect the delivery collector to the distribution collector by interposing vibration-damping joint. This connection can be done either on the right side or on the left side of the collector by displacing the blind flange or the threaded cover.

**ATTENTION!** It is a good rule to foresee the evacuation of water losses in case of bad seal of joints, mechanical seal, tanks overflowing, etc.

In the case where there would not be any pumping in close proximity from the group, on the discharge line, the installation of a test faucet is recommended.

It is necessary to control from time to time the pre-replenishment pressure of membrane vessel that must be 0.2÷0.3 bar lower than the minimum closing pressure of the pressure switch calibrated lower.

This control must be done without pressure in the installation or with the tanks disassembled.

## PRIMING OF THE GROUP

Refers to Fig. 1



Always shut off the voltage before proceeding to any operation.

**ATTENTION!** The group needs to be filled up before putting it in operation.

In case of aspiration with positive suction head, open storage, aqueduct or water pipe under pressure, prime the group as follows:

- open all valves and remove the priming plugs on the aspiration collector and on the pumps;
- open the water supply on-off valve until the evacuation of the liquid;
- close again the feed faucet and the pumping plugs.

In the case where the group supply is with lower suction head, underground well or tank, prime the group as follows:

- open all valves and to and remove the priming plugs on the aspiration collector and on the pumps;
- fill with water through the suction pipe;
- make the necessary topping-up through the priming plugs on the pump casing until complete filling-up
- re-assemble the plugs.

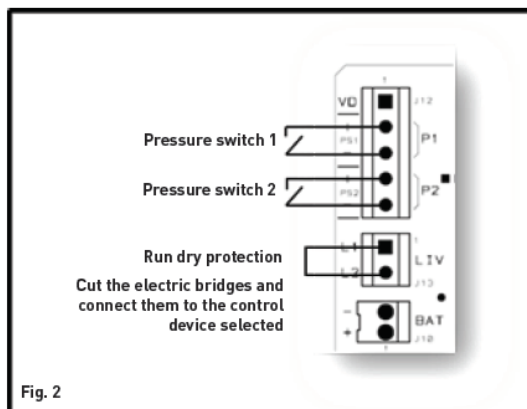

## ELECTRICAL CONNECTION



The panel must be powered by a differential device with on/off power under 30 mA.



Check that the power supply is provided with an efficient ground installation in accordance with the current regulations.

**ATTENTION!** The single-phase panel does not have a master switch.

**ATTENTION!** Check that the voltage and frequency indicated on the nameplate correspond to those of the available power grid.

**ATTENTION!** The power supply is equipped with differential circuit breaker with the sensitivity required by the regulations in force for this type of equipment.

**ATTENTION!** Before connecting the power supply cable to the control board, check that it has sufficient dimensions to support the maximum voltage required by group pumps.

**ATTENTION!** The connection of the distribution boards to the power grid must be done according to indications reported on the electric connection scheme situated in the control board.

Our units are delivered with "LIV" jump terminals (L1-L2 for the single-phase, Fig.1; 5-6 for the three-phases, Fig.2).

**ATTENTION!** In this case the unit is not protected against dry operation. It is therefore necessary to remove the electric bridges and connect them to the control device selected.

### Float switch

The float must be installed in the tank and connected thanks to two wires to the special terminals on the control board.

### Inverted minimal pressure sensor

In the case where the group is fed by a water duct under pressure (for example municipal water system), it is necessary to install a minimal pressure sensor which prevents from the working of the group if the pressure in the duct descends below the preset value.

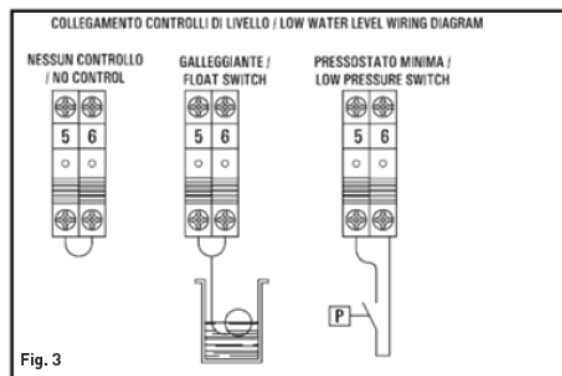

Single-phase unit

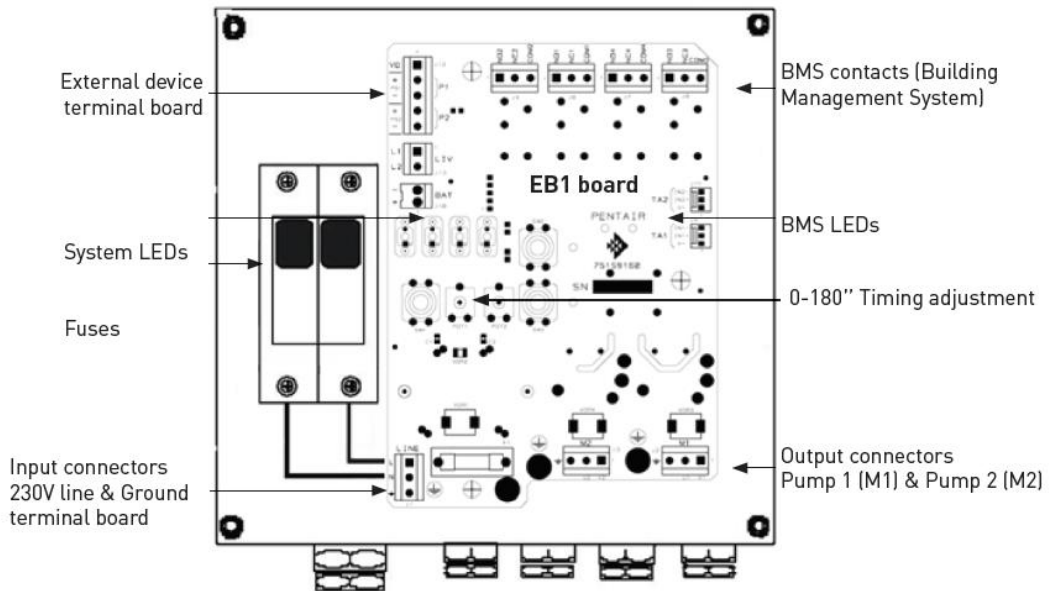
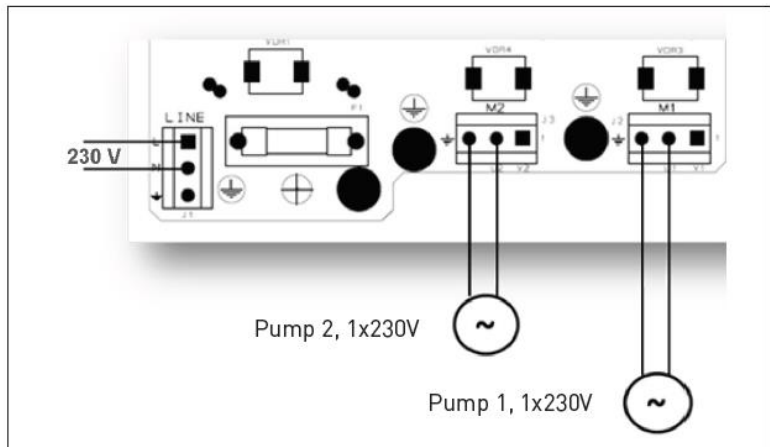
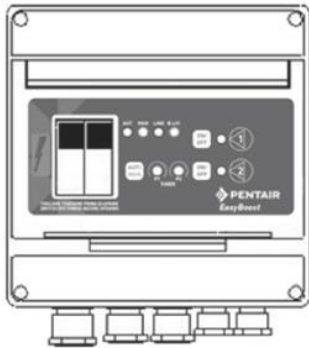
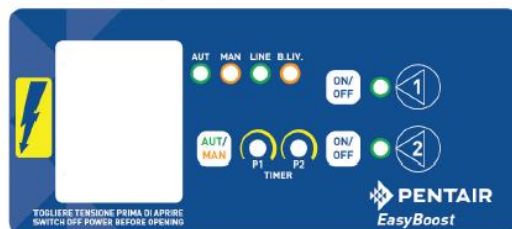

Fig. 4

AUT Green light for automatic mode  
 MAN Red light for manual mode  
 LINE Green light for power on



Green lights for running pump1 and pump2

Switch MAN/AUT

Switch ON/OFF Pump 1/2

Three-phase unit

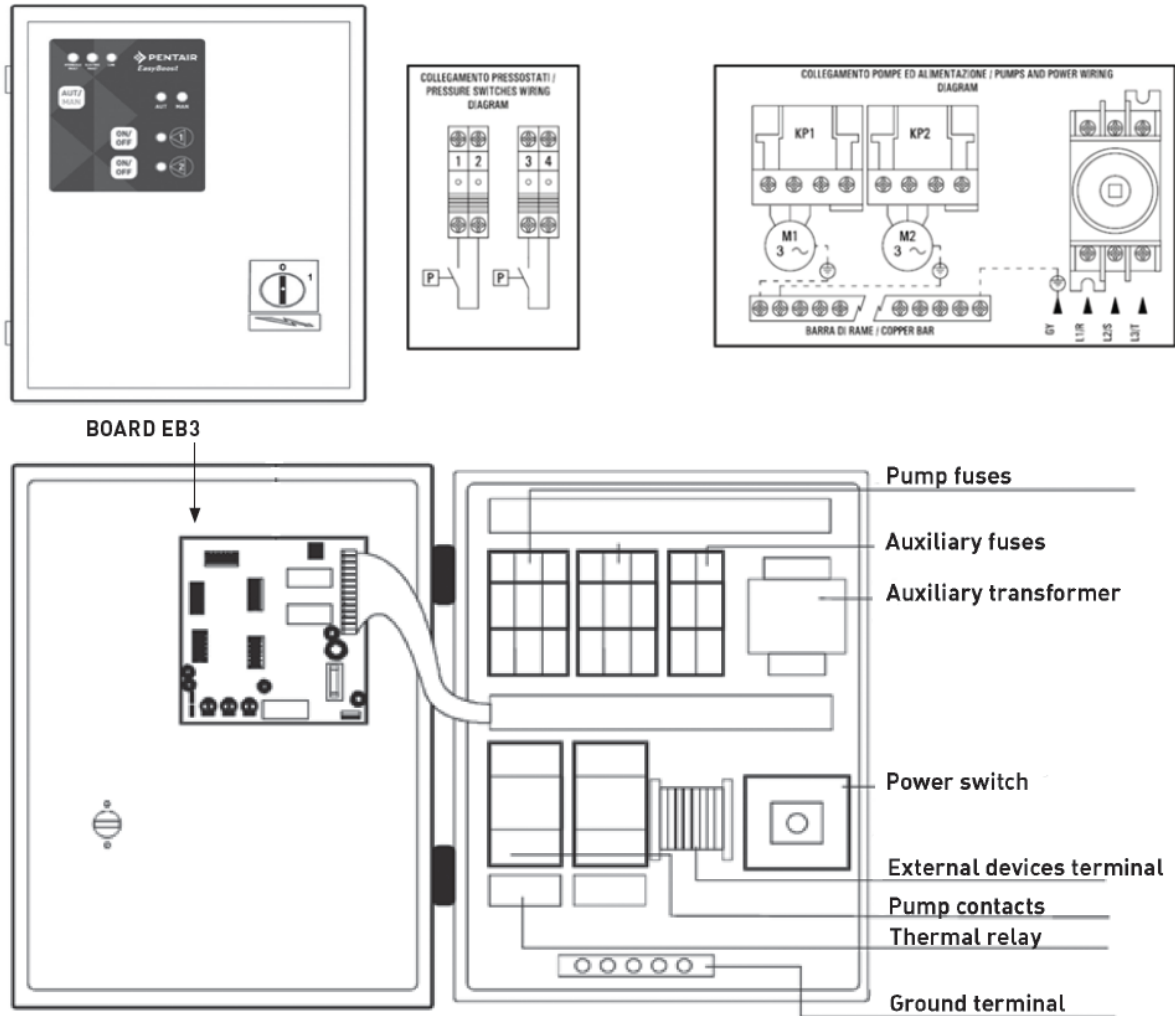

Fig. 5

HYDRAULIC FAULT = Red light  
 low level water tank  
 ELECTRIC FAULT = Red light for  
 thermal block  
 LINE = Green light for power on

AUT/MAN = Switch Automatic/  
 Manual

ON/OFF buttons



AUT - Green light for automatic mode  
 MAN - Red light for manual mode

Green light for running pump

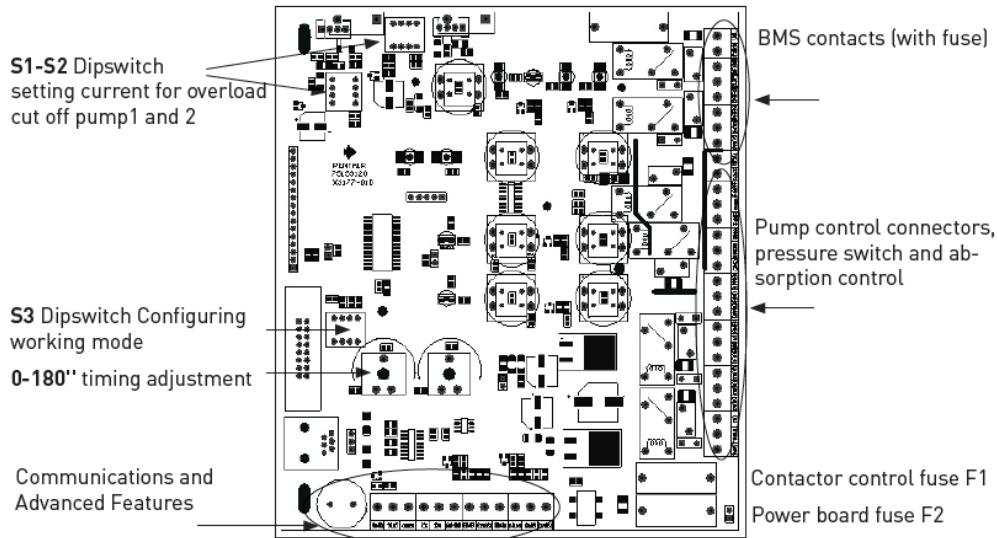

Fig. 6

## OPERATION

Once all the hydraulic and electric connections have been done for the hydraulic priming of the pumps and collectors, proceed as follows:

- close all the valves of the distribution system
- open all the valves of the group, included those of the membrane ways



From this moment any operations on pump ducts, pressure sensor, etc. must be done after having cut the voltage off from the distribution board.

Press the [AUT/MAN] pushbutton for MANUAL start and subsequently push the [ON/OFF] pushbutton to start the desired pump. Verify the rotational direction of the pumps.

### Check the direction of rotation (only three-phase pumps)

After starting the pump, press the [ON / OFF] button to stop the pump and check the direction of rotation. Perform the operation on all pumps.



If the two pumps have the direction of rotation reversed: Disconnect the power supply and invert two phases of the general power cable from the electrical panel.



If only one pump has the wrong direction of rotation: Remove power and reverse the wires in the terminals of the contactor power for that pump.

### Check the priming of the pumps

Keeping all the drawing valves closed:

- Press the [AUT/MAN] button for MANUAL mode start
- Start one pump and verify that max pressure is reached
- Stop the pump



Check that the circuit pressure reaches the maximum value. If not, repeat the filling operations of the collection of aspiration to the pump.

- Repeat the operation on the other pump

### Automatic Starting of the standard unit

After having forced pressure into the unit through the manual driving of the pump, set the pump selectors to the AUTOMATIC position.

From then on, the unit will automatically work according to the quantity of water withdrawn by its use.

### Change of the working pressure

Our units are set and tested during manufacture and the working pressure is set up according to the characteristic curve of the motor pumps used.

It is however possible to modify the working pressure value by changing the setting of the pressure switch used.



The values of pressure switch calibrations must be between the minimum and maximum working pressure levels foreseen for the pump used in the unit and reported on the plate applied to the pumps themselves.

- Cycle 1  
Pressure switch 1 -> Pump1 | Pressure switch 2 -> Pump 2
- Cycle 2  
Pressure switch 1 -> Pump 2 | Pressure switch 2 -> Pump 1
- Cycle 3  
Pressure switch 1 -> Pump 1 | Pressure switch 2 -> Pump 2

# ENGLISH

Automatic rotation of the pumps is carried out also if only one pump starts.

- Cycle 1: Pressure switch 1 -> Pump 1
- Cycle 2: Pressure switch 1 -> Pump 2

**ATTENTION!** For correct calibration of the pressure switches the following operations must be carried out exactly in the sequence reported.

**ATTENTION!** For correct calibration of the pressure switches the following operations must be carried out exactly in the sequence reported.

### Customized automatic starting of the booster



Always shut off the voltage before proceeding to any operation.

#### Single-phase version

In the standard configuration (jumpers JMP2 and JMP3 disconnected) the group operates in a cyclical manner (1duty - 1 assist). Acting on the configuration jumpers JMP2 and JMP3 on the card it is possible to modify the working mode.

JMP2 connected: Mode 1 duty - 1 standby: in this case one pump will be activated in a cyclic manner (except in case of alarm or removal of an electric pump). The reserve pump will be activated only in the event of an alarm or electric pump before the next cycle.

JMP3 connected: second electric pumpd excluded. This configuration can be used for example in the case of maintenance or if necessary to disconnect an electric pump from the group.

Note: The jumpers must be connected when the electric power is off.

#### Three-phase version

In the standard configuration, the group operates in a cyclical manner (1duty - 1 assist). By changing the positions of the contacts of the switch S3, located at the back of the card, it is possible to modify the working mode.

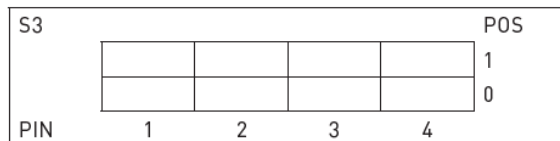

Pin 4 timing in automatic reset alarm (0: not active, 1: active).

Pin 3 determines the mode (0: second pump assists, 1: second pump standby)

Pin 2 cycles (0: active cycle - 1: cycle is not active)

Pin 1 determines the advanced control mode (communication / service).

#### S3=0000: 1 duty - 1 cycle assist (standard configuration)

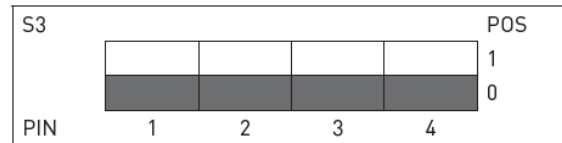

#### S3=0100: 1 duty - 1 non cycle assist (standard configuration)

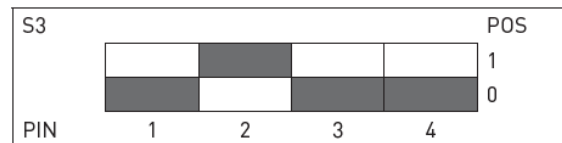

#### S3=0010: 1 duty - 1 cycle standby

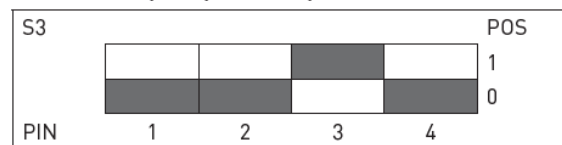

#### S3=0110: 1 duty - 1 non cycle standby

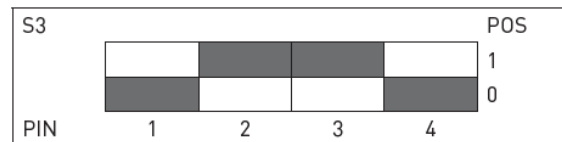

#### S3=0001 1 duty - 1 cycle assist

Rearming the electric timing alarm: After 5 minutes, the system will try three times to restart the electric pump under electric alarm condition.

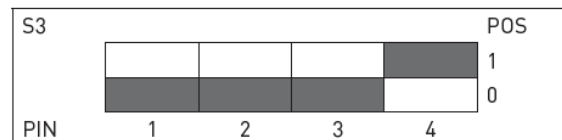

#### S3=1000 1 duty - 1 cycle assist

Advanced configuration (service): Note: this configuration disables the normal operation of the group.

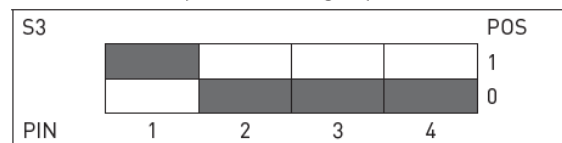

## Pressure switches calibration

### Calibration of the pressure switches mod. PY06

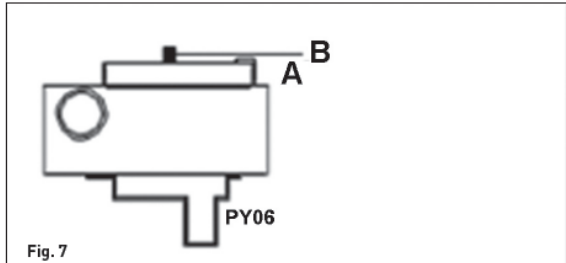

Fig. 7

- Tighten almost to the maximum screw A of the pressure switch
- Unscrew almost totally screw B of the pressure switch
- Close all the points of collection and bring the plant to the maximum pressure by manual use of pump. Stop the pump.
- Leave the switchboard predisposed for MANUAL operation.
- Open a point of collection and close it when the circuit pressure has reached the level which we intend to assign to the first pump.
- Tighten screw B of the pressure switch n.1 to the point where its electric contact closes.
- Manually use the pump to raise the network pressure and bring it to the level that we want to assign to the first pump.
- Unscrew screw A to the point where the pressure switch n. 1 is opened.
- Repeat the operation on the other pressure switch.

### Calibration of the pressure switches mod. PM/5 e PM12

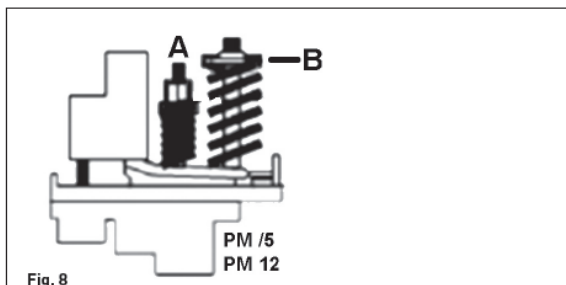

Fig. 8

- Tighten screw A of the pressure switch to half-way position.
- Unscrew screw B of the pressure switch.
- Close all the collection points and with a pump in MANUAL mode, slowly bring the discharge collector pressure up to reach the opening of the pressure switch contact (OFF).
- Open a small collector by bringing the pressure to the level (start pump) that we want to assign to pressure switch n.1
- Tighten screw B of pressure switch n.1 to the point where its electric contact closes (ON).
- With a pump in MANUAL mode, slowly bring the circuit pressure to the starting level (arrest pump) that we want to assign to the first pump.
- Unscrew screw A to the point where pressure switch n. 1 opens.

### Calibration of the pressure switches mod. XMP 12

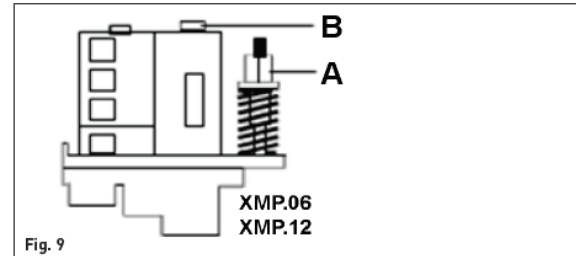

Fig. 9

- Tighten screw A of the pressure switch to half-way position.
- Tighten screw B of the pressure switch to half-way position.
- Close all the connection points and with a pump in MANUAL mode, slowly bring the collector discharge pressure to the opening level (stop/arrest pump) that we want to assign to pressure switch n.1 (the pressure switch contact must be closed - ON -)
- Unscrew screw B of pressure switch n. 1 to the point where its electric contact opens (OFF).
- Open a small collection/connection and slowly bring the circuit pressure to the closing level (start pump) that we want to assign to pressure switch n. 1
- Unscrew screw A to the point where pressure switch n.1 closes.
- Repeat the operation on the other pressure switch.

## ACTIVATION OF ELECTROPUMP TEMPORIZAZION

Temporization begins from the moment in which the thrust meter opens its contacts. Temporization is activated only in AUTOMATIC [AUT] mode.

**ATTENTION!** With temporization activated, the pumps can reach their maximum pressure. Check that this pressure is not harmful to the system, the distribution system or the devices.

Acting on the potentiometer of the desired pump, you can activate and inactivate the temporization of the pumps



Always shut off the voltage before proceeding to any operation.

### Single-phase pumps



The electronic card foresees the possibility of temporizing the functioning of the two pumps from a minimum of 3'' up to a maximum of 180''.

Rotating potentiometers P1 and P2 towards right, the switching-off time increases.

## Three-phases pumps

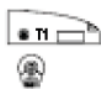

The electronic card foresees the possibility of temporizing a delayed switching-off of the last running pump subordinate to the pressure switch input, with a delay of a minimum 3" up to a maximum of 180".

Rotating the potentiometer T1 towards right, accessible on the control board inside the control panel, the switching-off time increases.

- The contact of one or more pressure switch is closed because of a calibrating defect = Calibrate the pressure switch(es)
- The connecting tube of the pressure switches are obstructed = Eliminate the obstruction
- The pressure switches cable is by-passed = Verify pressure switches electric connections
- The check valves are dirty or damaged = Clean or replace the valves
- The timing of the pumps is activated = Bring to the minimal operating time

## FUNCTIONING ANOMALIES

### The pumps do not start

#### All the pilot lights are off

- No power supply at the distribution board = Supply power to the distribution board
- The supply or the exit fuses of the transformer (three-phases version) are disconnected = Replace the disconnected

#### LINE pilot light and MAN pilot light are on

- The group is set to manual mode = Activate the AUTOMATIC mode pressing the [AUT/MAN] pushbutton

#### LINE pilot light on, B.LIV or HYDRAULIC FAULT pilot light on

- Lack of water in the first collection tank = Restore the water level
- The level control is not operating or is damaged = Install or replace the level control
- The level control is not operating due to the disconnected bridge = Verify the bridge

#### LINE pilot light on; AUT pilot light on; Running pump pilot light(s) on

- The fuses of one or more motor pumps are disconnected = Replace the fuses of the motor pump(s)

#### LINE pilot light on; AUT pilot light on; ELECTRIC FAULT pilot light on

- Overload or missing electrical absorption of one or more motor pumps = Verify the correct MANUAL mode selection. In case the pumps are working, reactivate the AUTOMATIC mode. On the contrary, contact the service center.

#### LINE pilot light on; AUT pilot light on; Running pump pilot light(s) off

- The pressure switches are not calibrated, disconnected or damaged = Control the pressure switches and their connections

### The motorpumps do not stop

#### LINE pilot light on; Running pump pilot light(s) on

- The pump(s) operate in MANUAL mode = Activate the AUTOMATIC mode pressing the [AUT/MAN] pushbutton

### The motor pumps do not reach the pressure reported on the nameplate

#### LINE pilot light on; Running pump pilot light(s) on

- Check valves partially obstructed = Clean the valves
- Shut-off valves partially closed or obstructed = Open entirely and clean the valves
- Reversed direction of rotation = Invert the direction of rotation of the motor pumps (three-phases version)
- Motor pump disabled = Eliminate possible air locks in the suction pipe or in the motor pump